

The key for
the chinese market:
european design
made in china

迈进国际市场
欧洲设计
中国制造

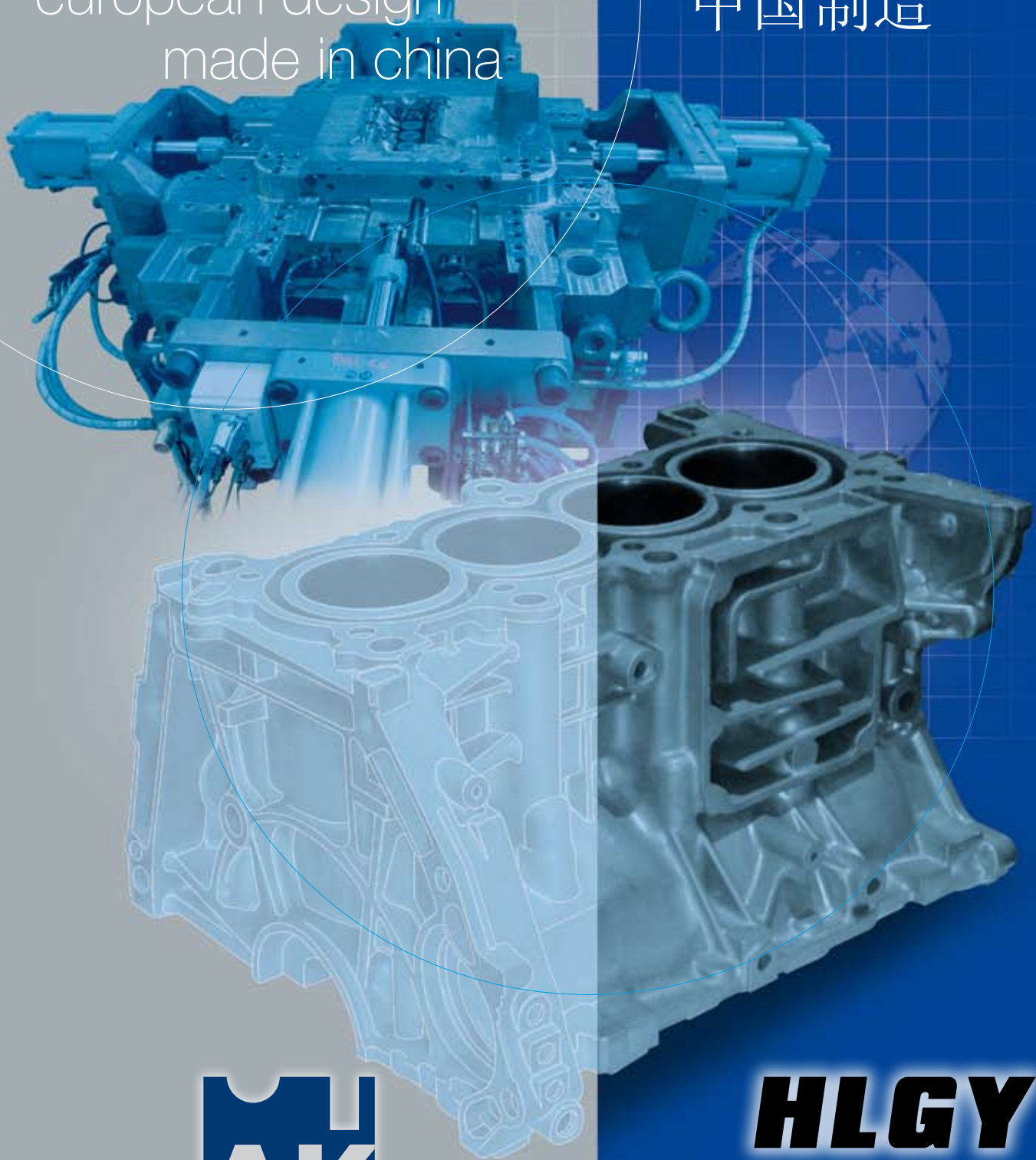

HLGY

Ningbo Heli Mould Technology Shareholding Company Limited (originally named Heli Mould Company Limited), established in the 80s, manufacturers all kinds of foundry moulds & patterns (High pressure, low pressure & gravity die-cast moulds, sand cast and moulding lines moulds, moulds for cold/hot core boxes, shell core boxes) .

HLGY

Our Technology Center consist of 50 highly skilful engineers is accredited as one of Zhejiang Province Enterprise Technological Center, supporting nearly hundred foundries in China, many of which have established long term partnership with Heli and part of the moulds supplied were exported to USA, England, Germany, France, Italy, Japan, Korea etc.

In 2006 Heli embarked an expansion program, it invested RMB 60 million adding new imported high precision equipments. The company employed highly experience design engineers and technicians that specialized in Automobile High Pressure die-cast mould for engine blocks, transmission main casting and other automobile accessories. All of which received full customers' satisfaction and endorsement.

In 2008, Heli have again invested another RMB 20 million putting 7 additional high precision equipment. Heli Mould have a current factory area of 41,000 square meter and built-up production area of 28,000 square meter; having more than 100 units of specialized mould making equipment, including imported high-speed large four-axis linkage boring and milling machining center, large-scale horizontal machining center, vertical machining center, five-axis high-speed machining center, high-speed with graphite suction system machining center, 22 units of gantry type double column machining center, 400T die spotting machine, 35 tons overhead crane, CNC electro sparking machine, smart-computer controlled wire cutting machines, large German made Wenzel CMM three dimensional laser scanning machine model-LH3020-400, UK made LK Coordinate Measuring Laser Scan Machine and other high-precision processing and testing equipment to ensure fast, efficient and precise mould manufacturing process.

With more than RMB 100 million worth of fixed assets, production capacity of RMB 200 million, in recent years Heli have been sequentially rated as "Contract abiding and highly Credible" enterprise by Ningbo City Government, "Superior" Enterprise by Xiangshan County Government, in 1999 achieving certification ISO9001:2000 quality systems and receiving "AAA" credit rating by Ningbo City Government.

宁波合力模具科技股份有限公司（原名宁波合力模具有限公司），成立于80年代，设计、制造各类铸造模具，包括高压压铸模具、低压铸造模具、重力铸造模具、砂型铸造模具及静压、气冲造型线模具、各种制芯机用的冷/热芯盒等。



公司技术中心拥有50多名高级专业设计人员，属浙江省企业技术中心。公司为全国近百家铸造企业配套，并与多家企业建立了长期合作伙伴关系，部份模具出口美国、英国、德国、法国、意大利、西班牙、日本、韩国等。

2006年合力投资6000万元进口新型高精密设备。公司聘请了具有丰富经验的模具设计工程师及专业技术人员，设计并制作的汽车发动机缸体压铸模具、变速箱压铸模具以及其它汽车零部件模具，模具质量得到客户的肯定与好评。

2008年合力投资2000万元增加了7台高精密设备。公司现占地面积41000平方米、建筑面积28000平方米，共拥有超过100台专业模具加工设备，其中包括进口高速、大型四轴联动卧铣镗、大型卧式、立式、五轴高速、高速石墨、龙门等22台加工中心，400T合模机，35吨行车，数控电火花成型机，德国温泽大型LH3020-400和英国LK三坐标测量机等各种高精度加工、检测设备，确保模具制造工艺流程快速、有效、准确。

公司拥有固定资产1亿元，年生产能力2亿元。近几年来，公司相继获得宁波市“重合同、守信用”企业、象山县“强势型”企业等称号。1999年通过ISO9001：2000质量管理体系认证；2009年通过ISO14001-2004环境管理体系认证、职业健康安全管理体系认证；银行资信等级达到“AAA”。

Partnership Agreement



By means of the AURRENAK-Heli Agreement, AURRENAK will provide the customer with the highest level of know-how and European design, combined with immediacy to the market and the excellent quality and expertise of Heli. The end result will be mould and tooling projects of the highest quality and technology adapted to the demands of the Chinese market. The aim of the AURRENAK-Heli agreement is to strengthen the presence of both brands in China through a partnership designed to jointly develop projects from the order book right up to delivery. AURRENAK and Heli have been working closely together since 2006, and in May 2009 it was decided to formalize a partnership agreement with strong foundations and growth targets for both companies. The growing interest of our joint customers in China to combine European design with local manufacturing has been the driving force behind this agreement in which both companies are committed towards providing the market with excellent results.

AURRENAK, located in the industrial area of the Basque Country, one of the most economically developed regions in Spain, is a company specialising in the DESIGN AND MANUFACTURE OF TOOLING FOR THE IRON AND ALUMINIUM CASTING INDUSTRY within the international automotive sector.

AK公司位于西班牙经济最发达的地区之一，巴斯克地区工业园区。是一家专门为全球汽车工业铸铁、铝合金零部件提供工艺和工装设计和制造的国际化企业。



AURRENAK was founded in 1974, having evolved steadily since then. During the 80's, the first numerical control milling machines and copiers are introduced, as well as the first 2D design layouts.

AK成立于1974年，自此一直稳步发展。

在80年代，AK采用了当时最新的数控铣床和仿形机床，并最先采用二维设计。

At the beginning of the 90s, AURRENAK introduces the first 3D CAD/CAM applications and becomes part of the Mondragon Corporation. During this decade, AURRENAK begins to manufacture aluminium injection moulds, being the first European company to supply HONDA with dies. It is awarded the ISO 9001 quality certificate and expands its facilities.

90年代初，AK率先使用三维CAD/CAM设计和制造，加入并成为蒙德拉贡集团成员。在这十年中，AK开始生产铝浇注模具，成为第一家为本田汽车供应压铸模具的欧洲公司。

Since 2000 we have renewed our offices and set up a test area (low pressure, high pressure and core tooling production), consolidating our international market, with a new customer oriented organizational model.

公司荣获ISO9001质量体系认证。自2000年以来，公司重新更新了办公和设施，设立了试验区（低压浇注、高压压铸和芯制造生产测试），巩固了国际市场并创立了以客户为导向的组织模式。

In 2003, AURRENAK joined forces with Loramendi to offer its customers a turnkey project, with a significant global presence via their sales offices.

2003年，AK与Loramendi正式联合，通过其全球销售体系为客户提供交钥匙项目和工程服务。

In 2009 AURRENAK signed a partnership agreement with Ningbo Heli Mould Technology Shareholding Co. Ltd, to secure a position within the Chinese market.

2009年，AK与宁波合力模具科技股份有限公司签署合作协议、确保并扩展在中国市场的地位。

伙伴关系协议

在AK 与合力签署了合作框架内，AK 将提供最高级别的技术及欧洲设计、结合即时的市场反应及合力的优良品质与专业知识、将提供高质量、适应中国市场要求的模具及工装项目。

AK 与合力合作协议将加强两企业在中国的品牌地位。双方合作共同开发项目，从合同订单一直到交付用户使用、生产。

自2006 年以来，AK 与合力开始密切合作，终于2009 年5 月两家公司在坚实的合作基础与共同的发展目标下正式签署合作协议。客户对欧洲设计技术结合本地制造成本的项目日益需求成为本协议的推动力，将注定为两家公司开辟良好的市场前景和优异业绩。

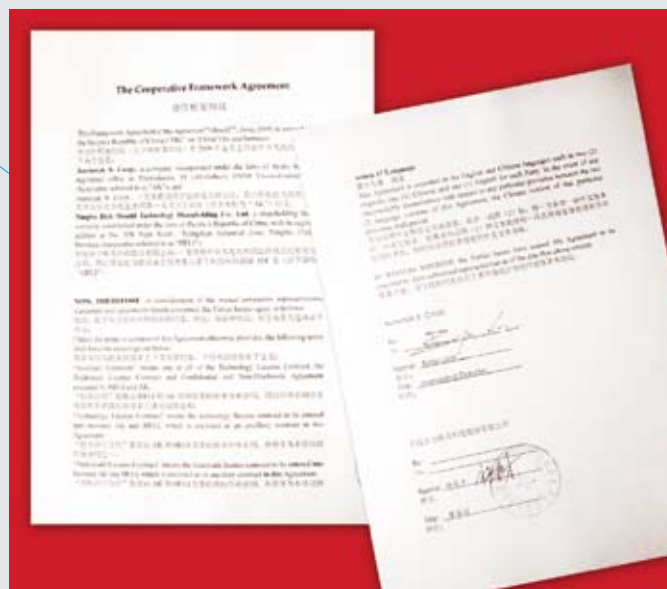



European design

欧洲设计

AURRENAK designs the tooling using the most advanced CAD/CAM design software tools.

From design to complete industrial integration, the AK team develops and produces all necessary elements for tooling manufacture, verification and assembly.

Ak has recognized that focusing on the quality of final data, CAD geometry and technical documentation will result in the best opportunities to compete in an ever-changing technological environment.

AK 采用最先进的CAD / CAM 设计软件和工具。

从工艺设计到完整的产业一体化, AK 团队具备工装制造、检验、装配和调试所需的完备技术和验证手段。

AK 认识到并注重最终数据质量、CAD 几何和技术文件、最终在不断变化的技术环境中最好地把握竞争机会。

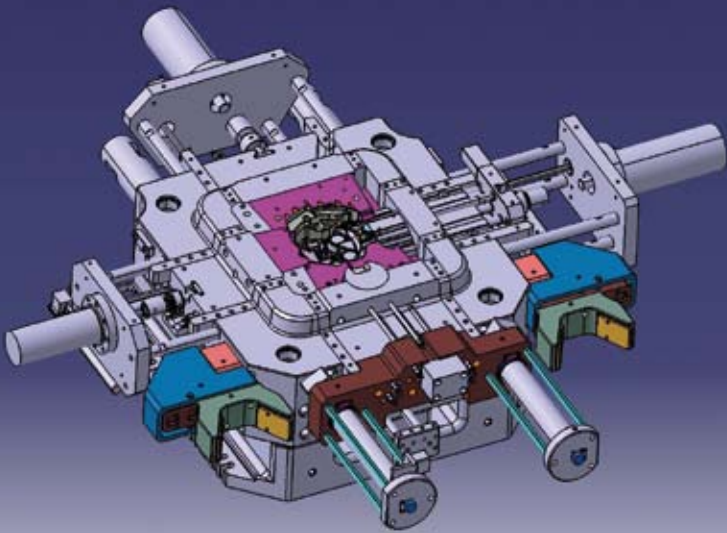
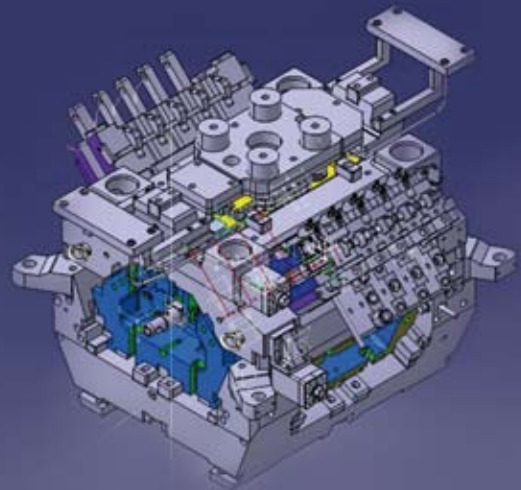
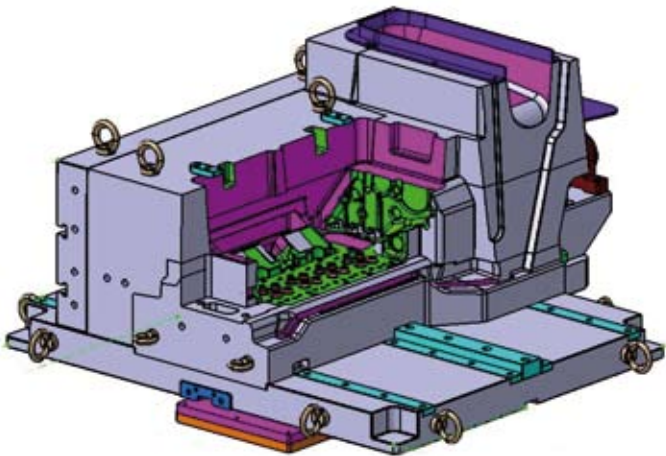

HLGY

High-standard die manufacture

高水平的模具制造

Heli manufacturers all kind of high-pressure die-cast moulds, low pressure die-cast moulds, gravity casting moulds, green and sand casting moulds; serving the automobile, electric motors, pumps, valves, machinery industries and is highly regarded in the Foundry Industries. The Company establishes its quality policy on "Creating Contemporary Product excellence and providing customer with excellent service"; with the assurance of ISO9001 quality system.

合力制造各种高压压铸模具、低压浇注模具、重力铸造模具、树脂砂和潮模砂造型等模具，产品覆盖汽车、机车、电机、水泵，阀门，机床等行业。产品质量得到客户的肯定与好评。公司以“创时代精品，为客户提供最佳服务”的质量方针为宗旨，以ISO9001 质量体系为保障，本着质量第一、诚信为本的原则，精心制作精品模具、铸就合力国际品牌。





International References 国际业务参考资料

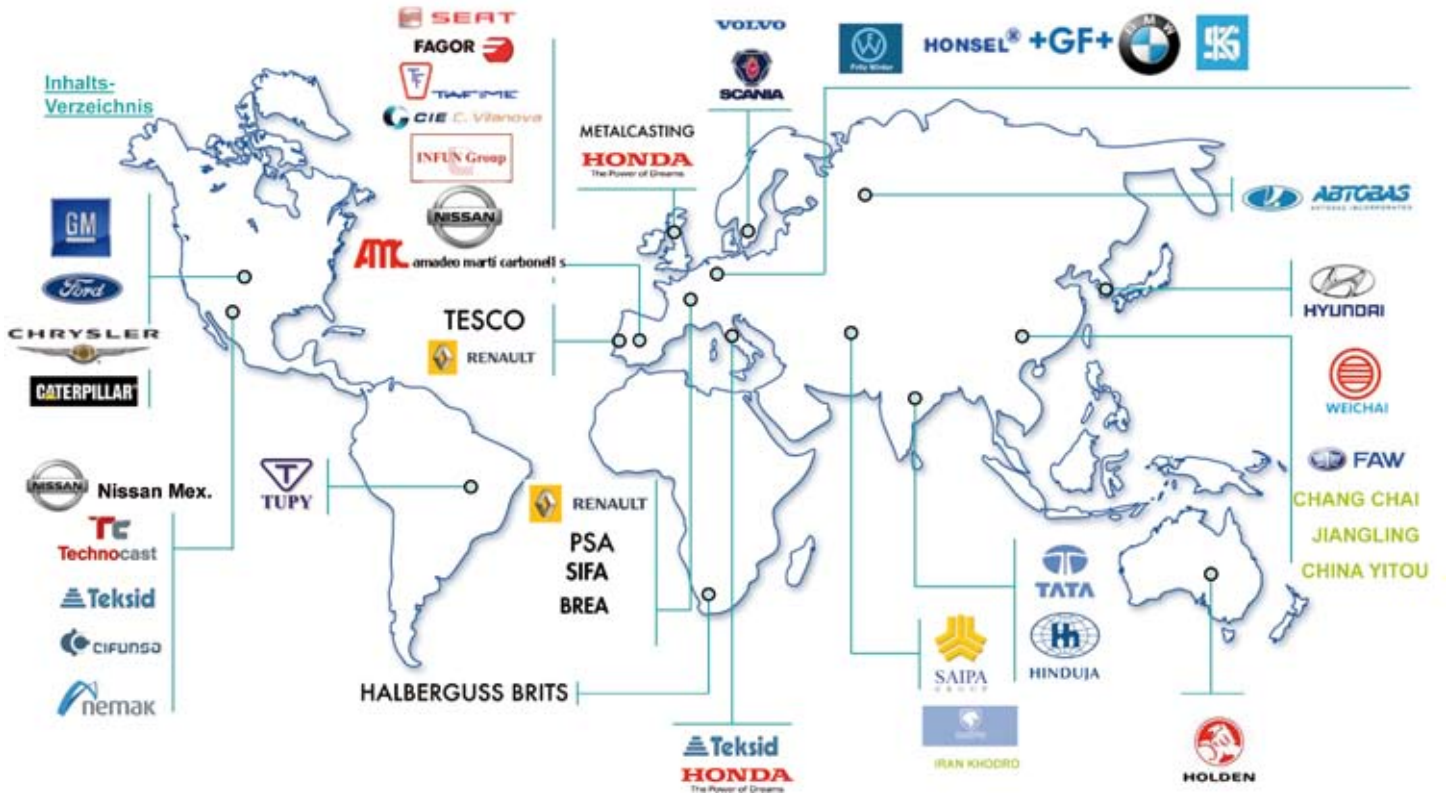

HLGY Chinese Market 中国业务参考资料



1. SHANGHAI COSMOPOLITAN AUTOMOBILE ACCESSORY CO., LTD
2. FAW FOUNDRY CO.,LTD
3. DONGFENG MOTOR CORPORATION NO.1 FOUNDRY
4. DONGFENG MOTOR CORPORATION NO.2 FOUNDRY
5. FOUNDRY BRANCH DONGFENG MOTOR CO.,LTD
6. HAFSIH DONGSAN ENGINE JOINT-STOCK CO.,LTD
7. BEIJING FUTIAN SHENYANG FOUNDRY FACTORY
8. TIANJIN TOYOTA MOTOR ENGINE CO.,LTD
9. SHENYANG AEROSPACE MITSUBISHI MOTORS ENGINE MANUFACTURING CO.,LTD
10. SHANGHAI SANJIAN CASTING CO.,LTD
11. HUI DONG TEKSID AUTOMOTIVE FOUNDRY CO.,LTD
12. NANJING TEKSID ALUMINUM FOUNDRY CO.,LTD
13. DONGFENG HONDA AUTO PARTS CO.,LTD

14. ANHUI JIANGSHI AUTOMOTIVE CO.,LTD
15. TIANJIN FAW XIAU AUTOMOBILE CO.,LTD
16. ABRACO INTERNATIONAL CASTING CO.,LTD.(SHANGHAI)
17. JIANGLING FOUNDRY FACTORY
18. TOYOTA INDUSTRY (KUNSHAN) CO.,LTD
19. KOLBENSCHMIDT PIERBURG (SHANGHAI) NONFERROUS COMPONENTS CO.,LTD
20. TAKAOKA LICHU (TIAN JIN) INDUSTRIES CO.,LTD
21. FUJUA MACHINERY INDUSTRY (KUNSHAN) CO.,LTD
22. KIRU-LIUCHU CO.,LTD
23. LIHO CASTING INDUSTRY (KUNSHAN) CO.,LTD
24. SHANGHAI SANDMANN FOUNDRY CO.,LTD
25. MCQUAY AIR CONDITIONING & REFRIGERATION (SUZHOU) CO.,LTD
26. COMBIPLAST PROJECTS,S.L
27. SHANGHAI GM DONGYUE POWERTRAIN COMPANY LIMITED
28. SAINT-OBAN (MAANSHAN) FOUNDRY CO.,LTD
29. SHANGHAI WANTAI AUTOMOBILE COMPANY CO.,LTD
30. SEW-EURODRIVE (TIANJIN) CO.,LTD
31. ATLAS COPCO AIRPOWER IN V.
32. RINGBO YEONG-SHANG CASTING IRON CO.,LTD
33. RINER MONGOLIA FIRST MACHINERY GROUP CORPORATION/CHINA NORINCO GROUP 1ST SUB-COMPANY
34. CHANGCHENG SUZUKI MACHINE & FOUNDRY CO.,LTD
35. SHANGHAI LUGONG MACHINERY CO.,LTD
36. SHANGHAI GENERAL FOUNDRY AND FORGING WORKS
37. JAMUSI ELECTRIC MACHINE CO.,LTD
38. VICTALUIC U.S.A
39. GUANGXI YUJIAH MACHINERY CO.,LTD
40. SAM WANG CAST IRON CO.,LTD
41. SHENYANG AERO XINGGUANG AUTO PARTS CO.,LTD
42. SHENYANG AERO XINGGUANG AUTO PARTS CO., LTD
43. AS. MONDRIAGH COOPERAZIONE COOPERATIVA
44. WUHU YANGDA TECHNOLOGY CO., LTD

Grey Iron Tooling

灰铸铁模具

Pattern Plates 型板

Core Boxes 芯盒

Fixtures 夹具



High Pressure Die Casting

高压压铸

Dies 压铸模具

Trimming Dies 修边模, 切边模



Low Pressure Die Casting

低压浇注

Dies 金属模具

Core Boxes 芯盒



Aluminium Dies: Gravity Casting

重力铸造

Dies 金属模具

Core Boxes 芯盒

Die Casting Machines 压铸机





www.aurrenak.com
www.helimould.com

AURRENAK SPAIN

Vitorialanda, 15 (Ali-Gobeo)
01010 Vitoria-Gasteiz · SPAIN
P.O Box: 1561
Tel.: (34) 945 24 48 50
Fax: (34) 945 24 69 12
E-mail: ak@aurrenak.com

AURRENAK CHINA

Landmark Tower A unit 1601
8 North Dongsanhuan Road
Chaoyang Dist. 100004 Beijing, China
Tel.: 86-10-6462 2139
Fax.: 86-10-6462 2140
E-mail: akchina@aurrenak.com

AK 中国代表处

北京市朝阳区东三环北路8号
亮马河大厦A座1601室
邮编: 100004
电话: 010-6462 2139
传真: 010-6462 2140
电子邮箱: akchina@aurrenak.com



NINGBO HELI MOULD TECHNOLOGY SHAREHOLDING CO.,LTD

No.358 Xigu road, Xiangshan County
Industrial park, Xiangshan County
Zhejiang province, China
Postcode: 315700
Tel: 0086-574-65724681
Fax: 0086-574-65724167
E-mail: nbheli@cnool.net

HLGY

象山县工业园区西谷路358号象山县，
浙江省，中国。
邮编: 315700
电话: 0086-574-65724681
传真: 0086-574-65724167
电子邮箱: nbheli@cnool.net